

CUSTOM SILLS AND CAP UNITS

4x4x16 SILL UNIT - $\frac{3}{4}$ " x $\frac{3}{4}$ " CHAMFER

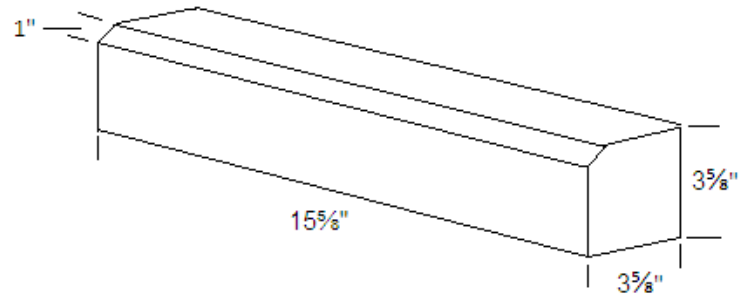

4"x4"x24" CHAMFERED SILL

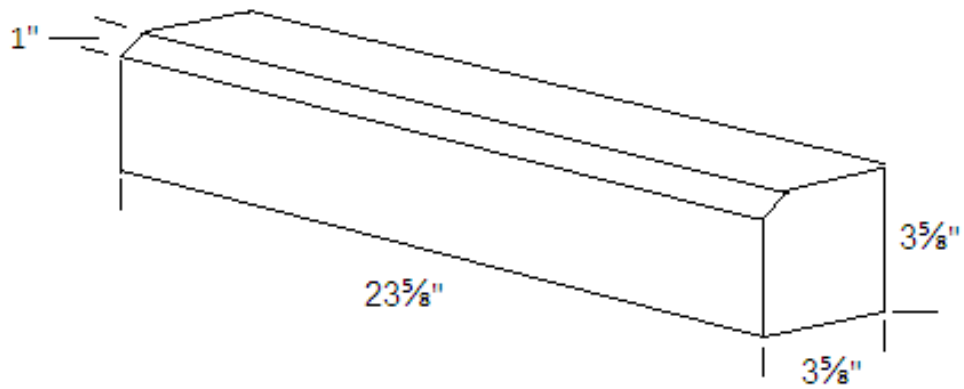

4 x 6 x 16 Bullnose Sill Unit

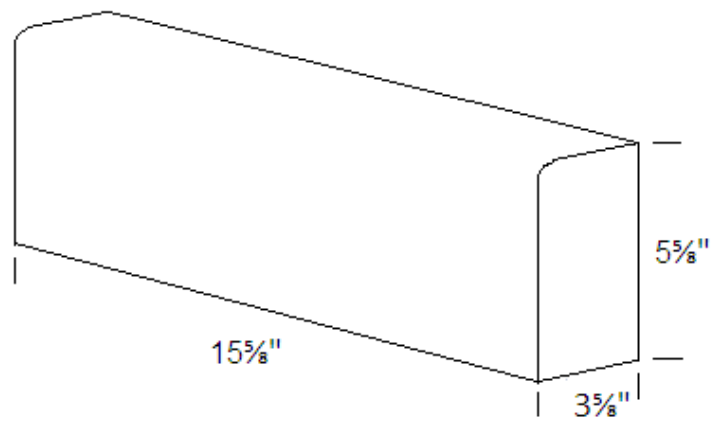

4x8x16 Solid Bullnose Sill Unit

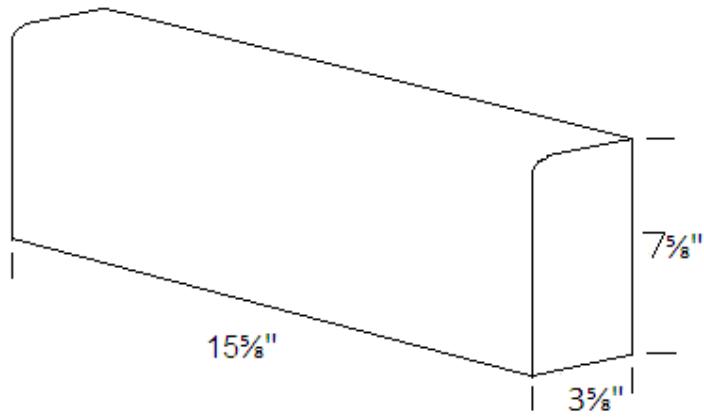

4"X8"X16" SILL w/ $\frac{3}{4}"$ X $\frac{3}{4}"$ CHAMFER

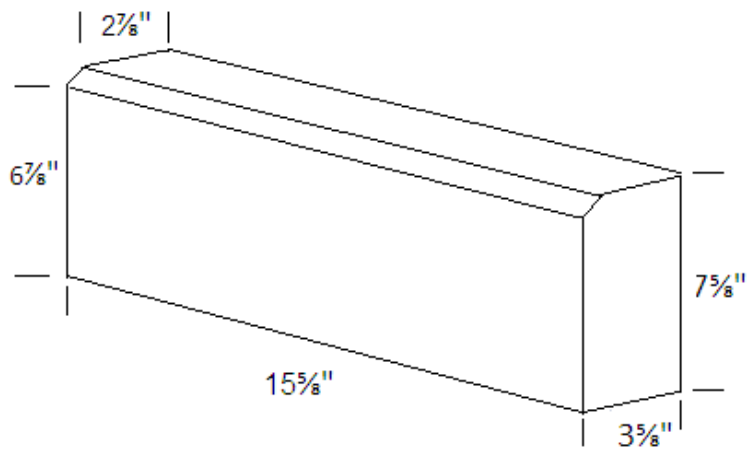

4x8x16 SILL w/ 2"x2" CHAMFER

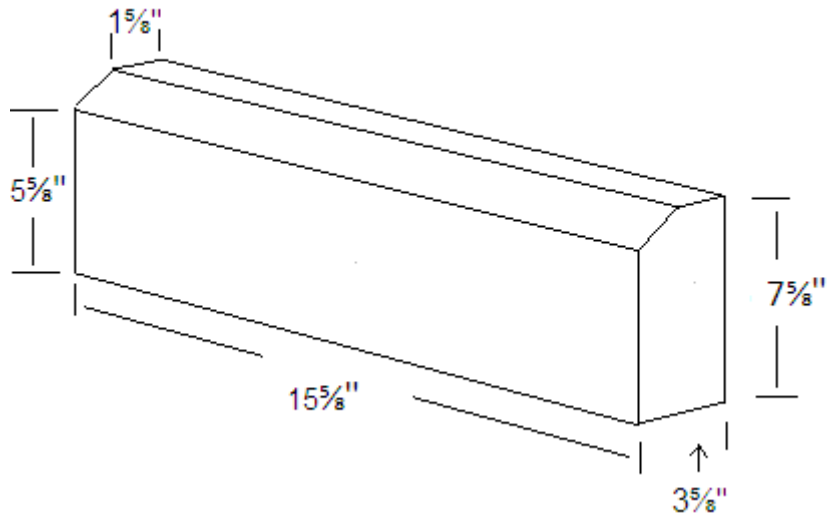

4x8x16 SLOPED SILL UNIT

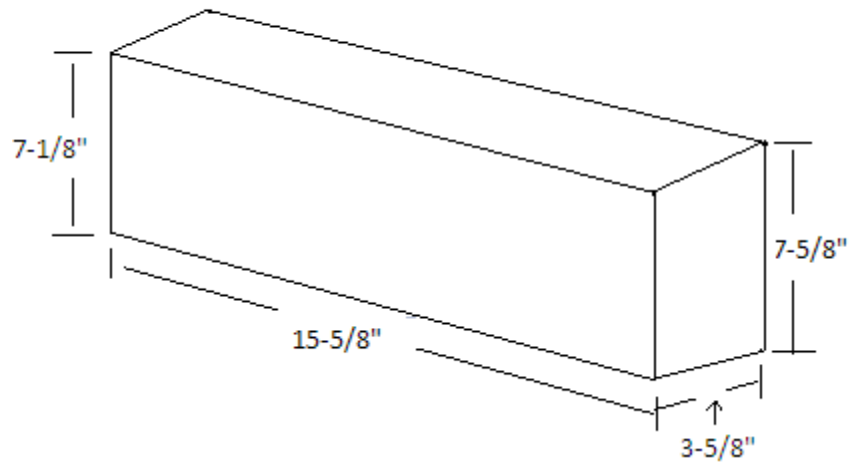

4x8x16 SOLID SILL w/ 2" x 1" CHAMFER

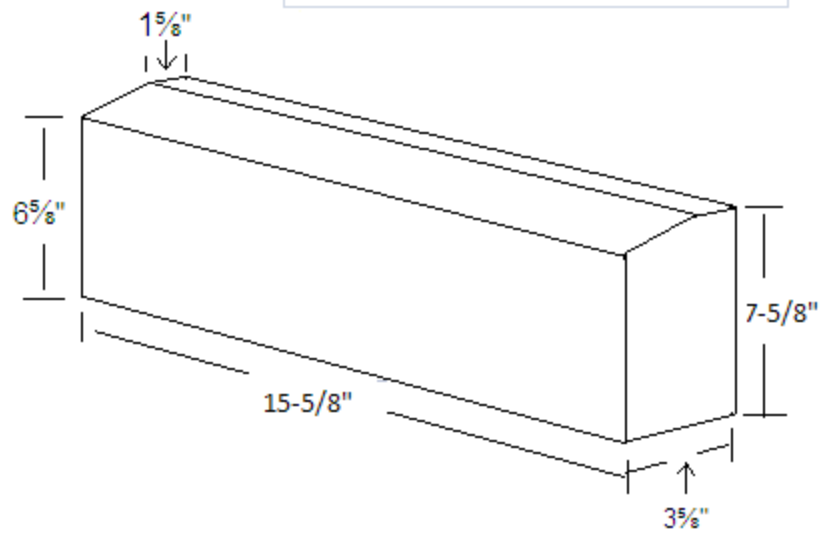

4"x8"x16" SPLITFACE SILL w/ $\frac{3}{4}$ "x $\frac{3}{4}$ " CHAMFER

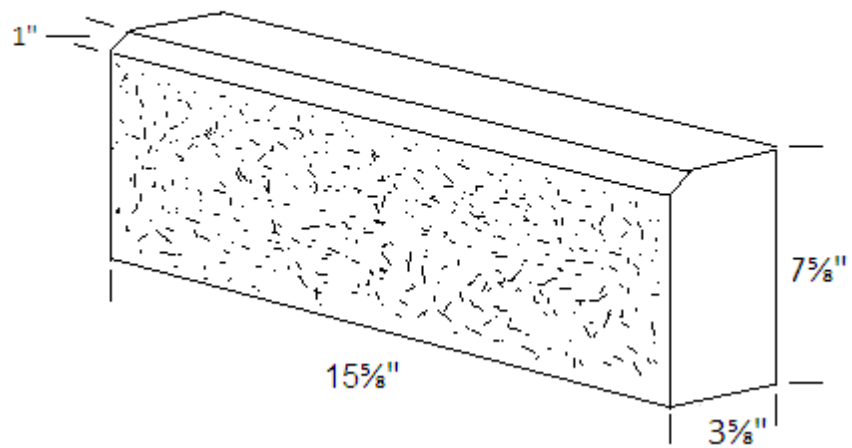

6x8x16 CHAMFERED SILL UNIT

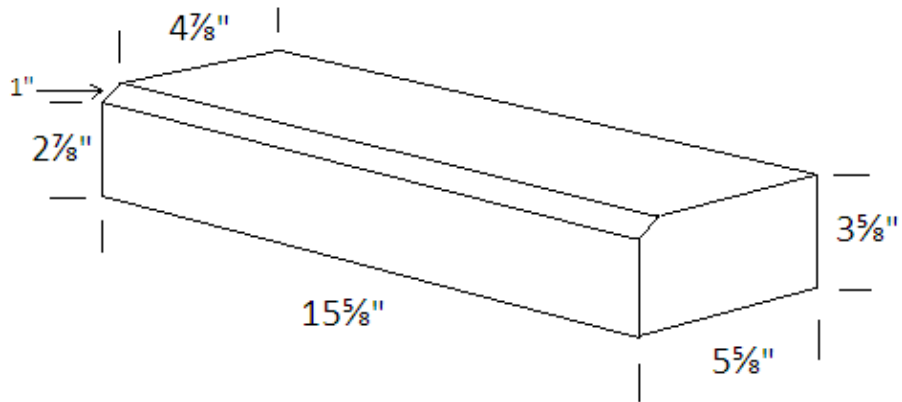
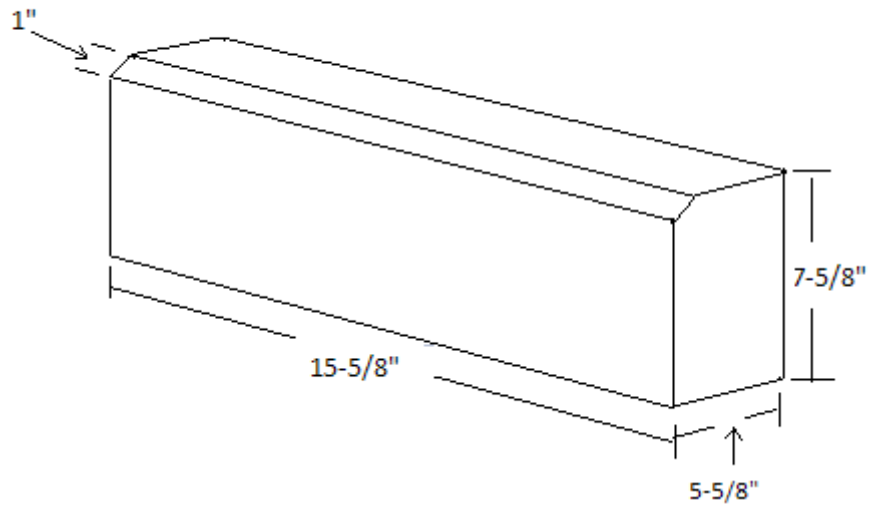

6x4x16 Sill Unit with 3/4" x 3/4" Chamfer

4x8x16 SCORED SILL with 1 1/2" x 1 1/2" CHAMFER

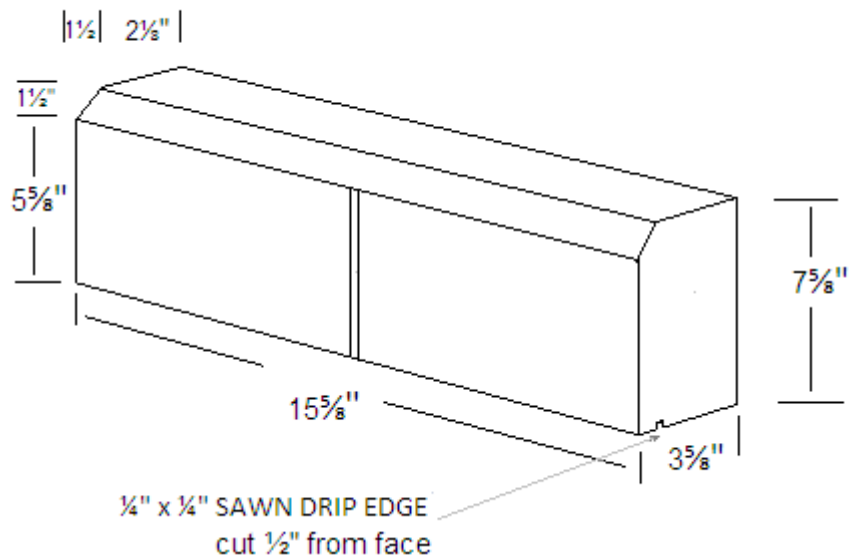

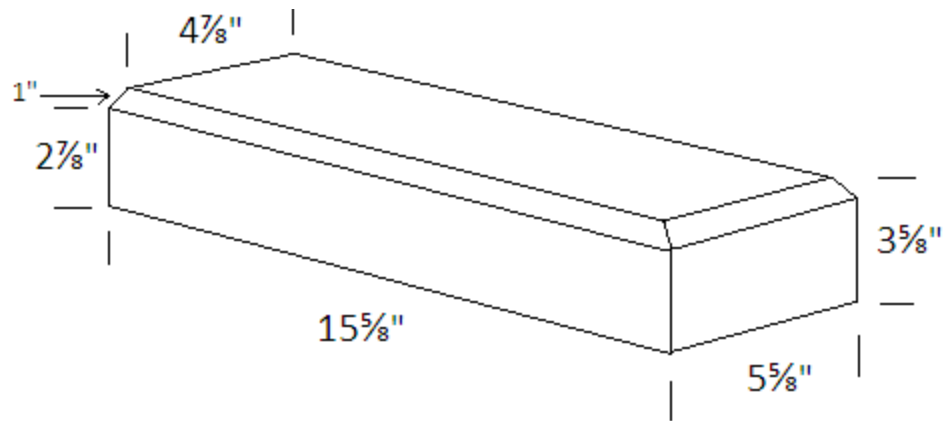

6x4x16 Sill Unit - $\frac{3}{4}$ " x $\frac{3}{4}$ " Chamfer and Chamfer Return

6 x 4 x 24 Bullnose Sill Unit

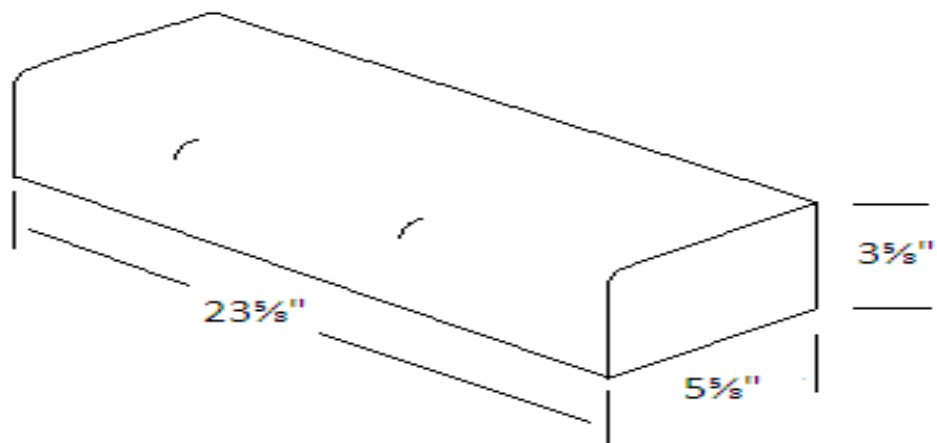

6X6X16 CHAMFERED SPLITFACE SILL

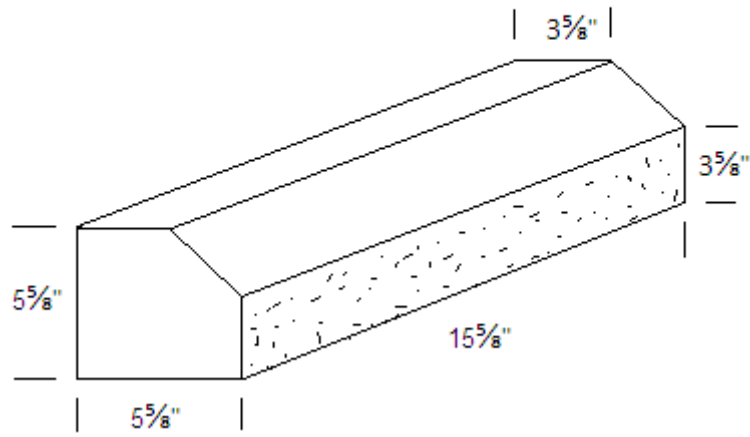

6x8x16 CHAMFERED SILL UNIT RIGHT RETURN

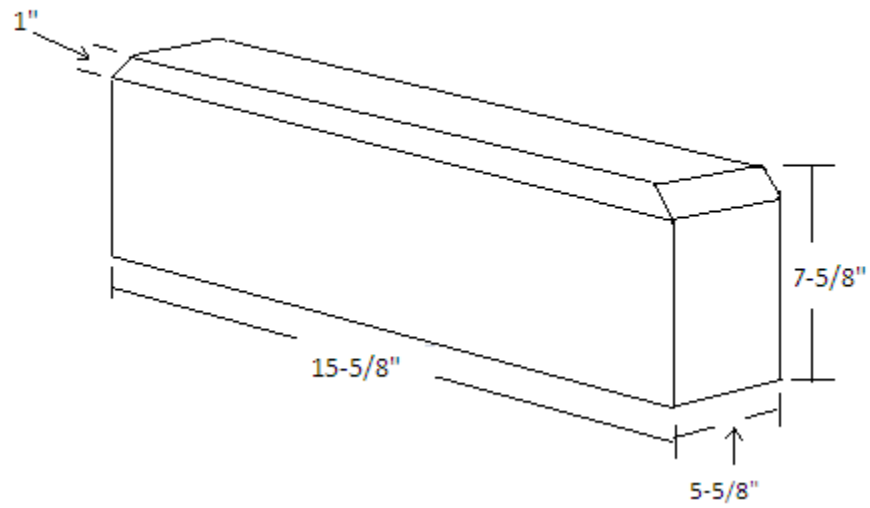

6x8x16 CHAMFERED SPLITFACE SILL

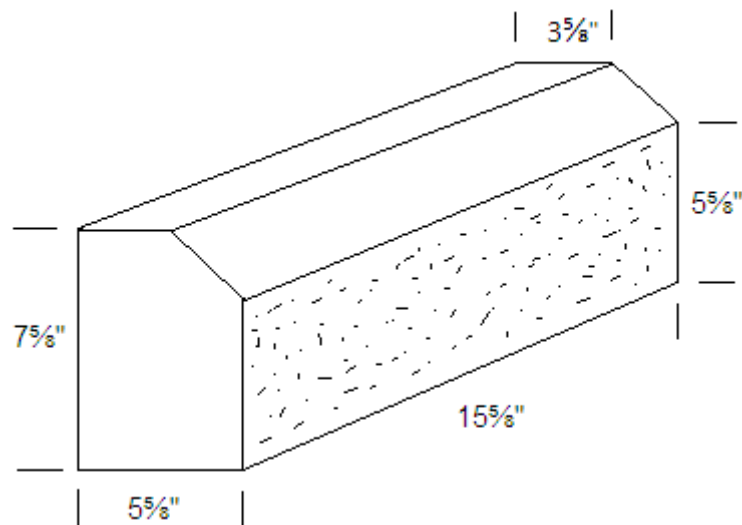

6x8x16 SILL with 2" x 2" CHAMFER

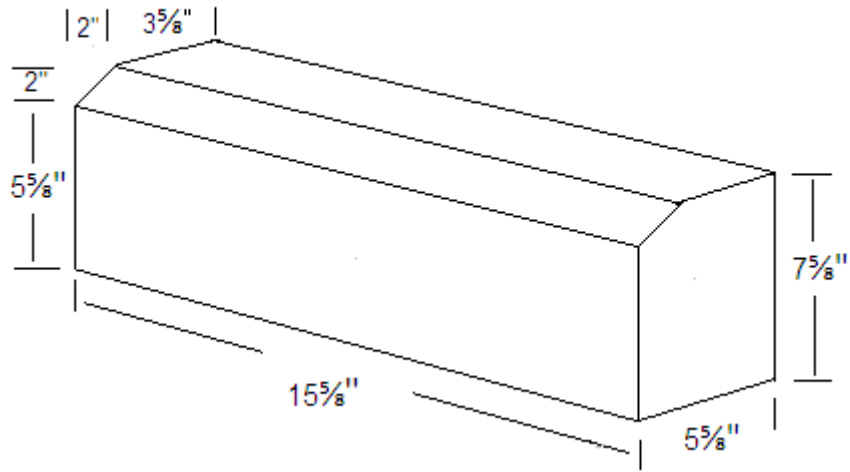

6x8x16 SILL UNIT w/ 2"x2" TOP EDGE CHAMFER

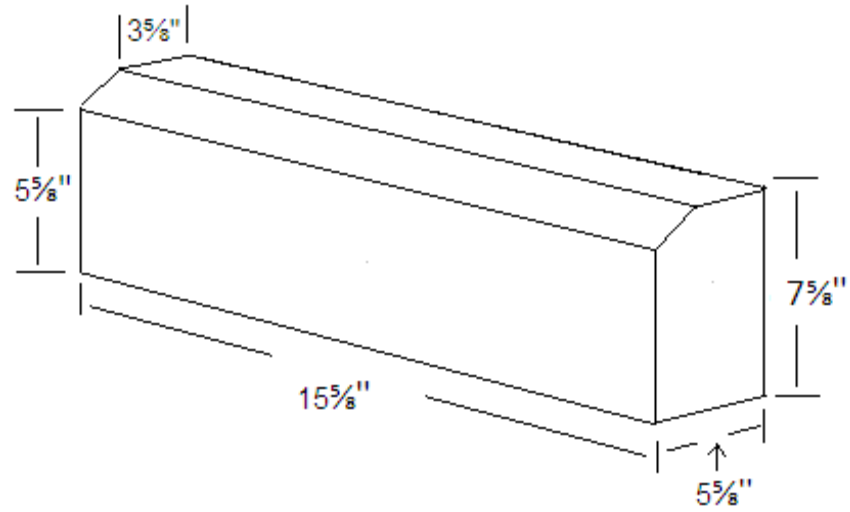

6x8x16 SILL with 2" x 2" CHAMFER

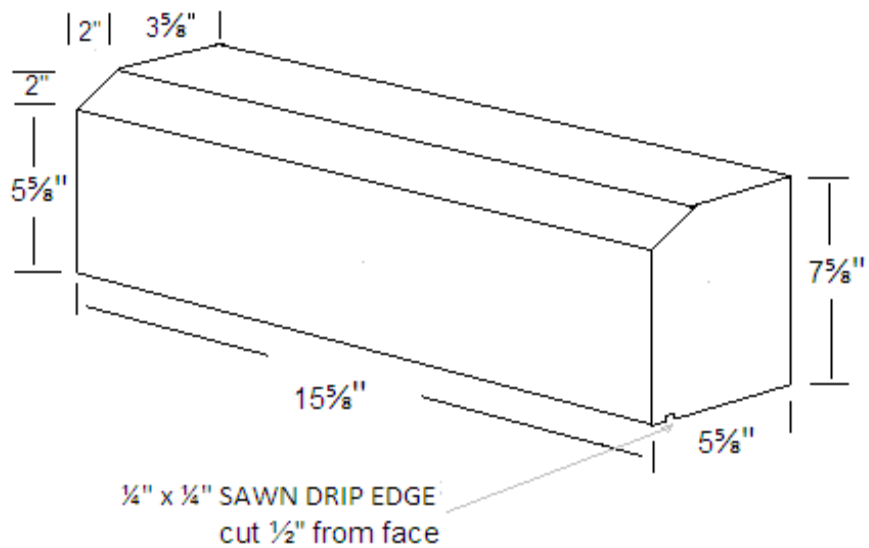

6x8x16 SOLID SLOPED SILL

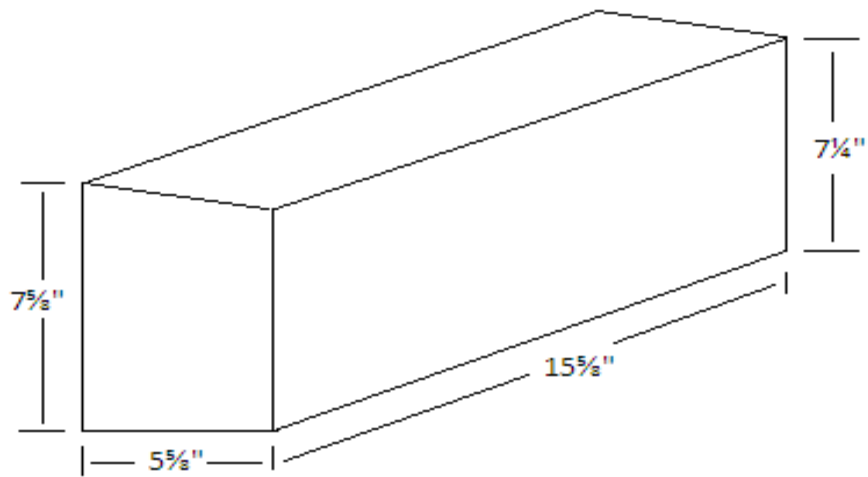

6X6X16 CHAMFERED SPLITFACE SILL

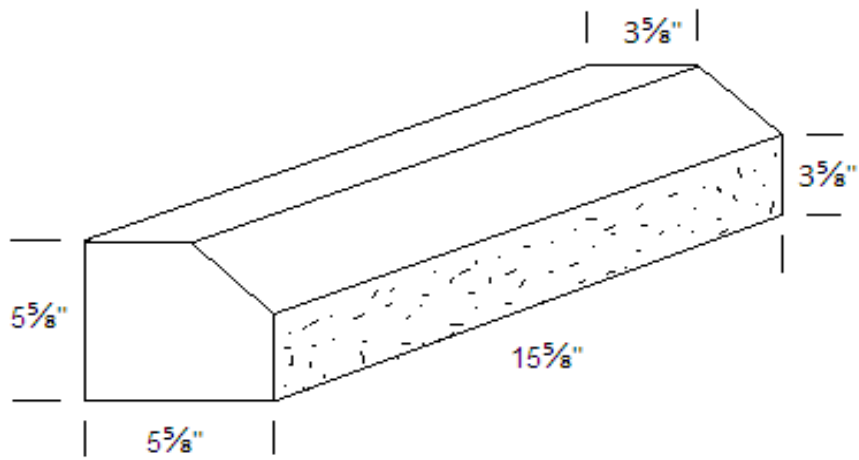

8x8x16 SOLID SLOPED SILL UNIT

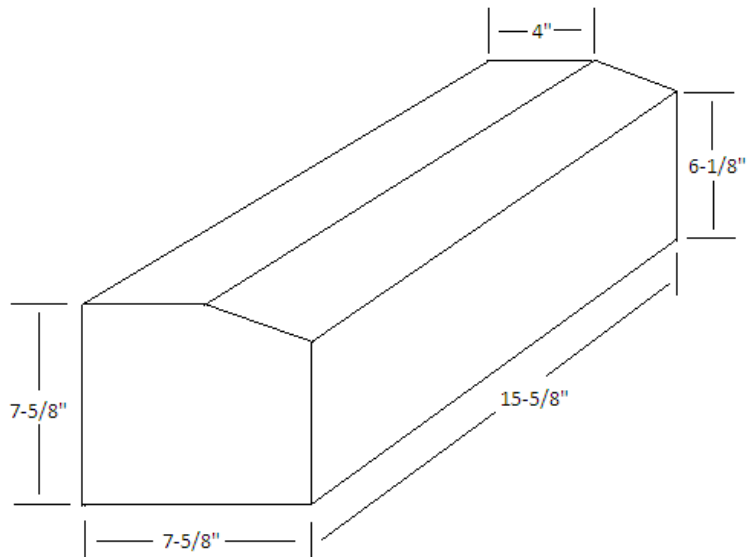

8x4x16 SILL UNIT w/ BULLNOSE TOP FRONT EDGE

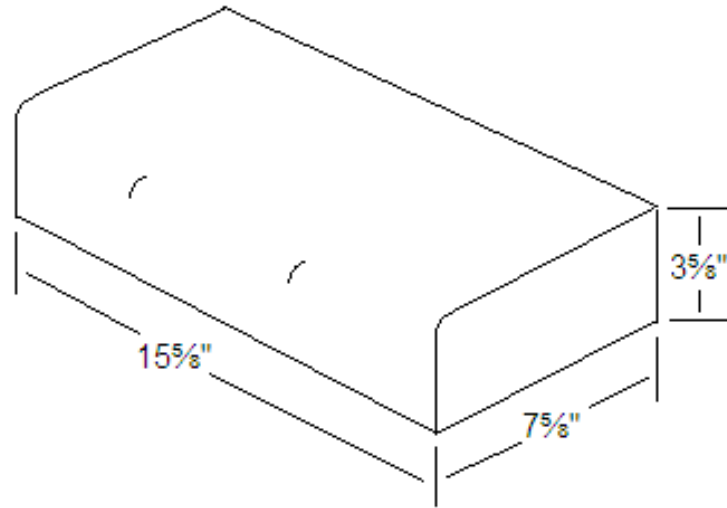

8x4x16 Solid Sill with 2" x 2" Chamfer

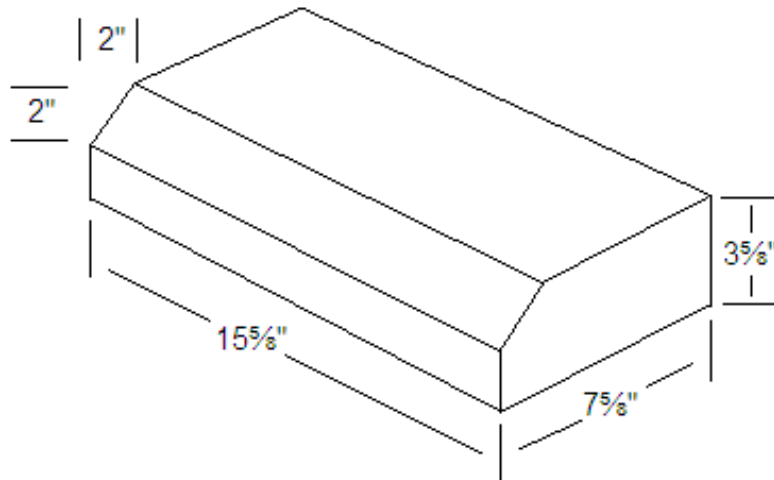

8x4x16 Solid Sill with $\frac{3}{4}$ " x $\frac{3}{4}$ " Chamfer

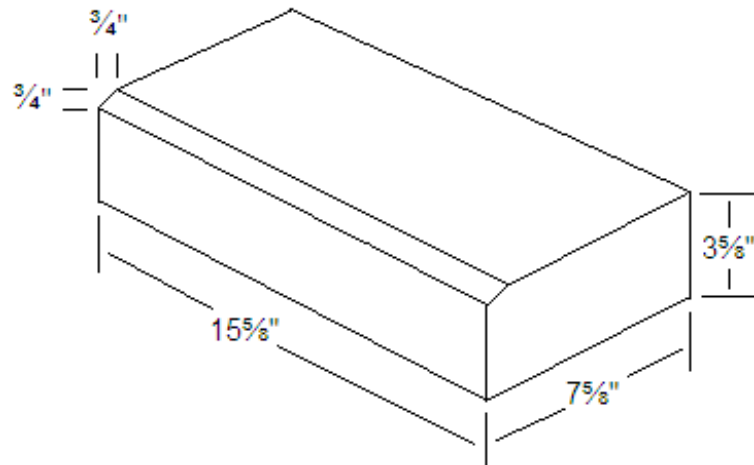

8x8x16 Solid Sill - 1Face, 1Top, 1BN Top Edge, 1 End

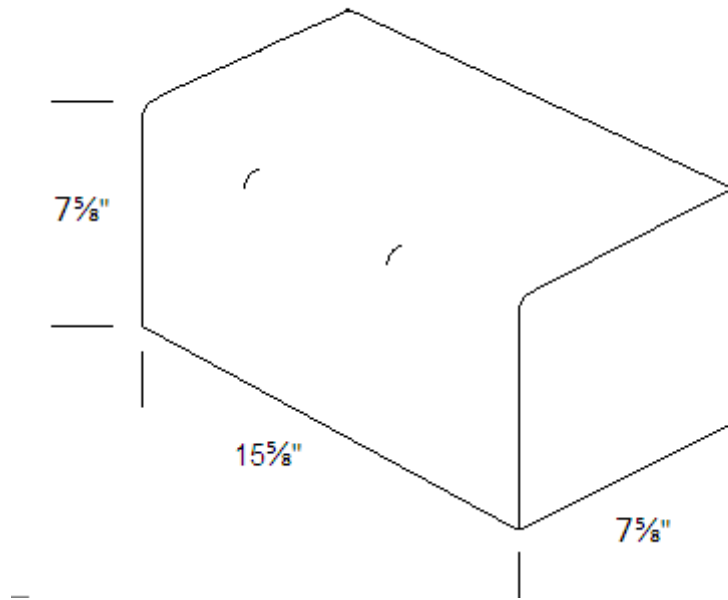

8x8x16 SOLID SILL - BULLNOSE TOP FRONT & BACK EDGE

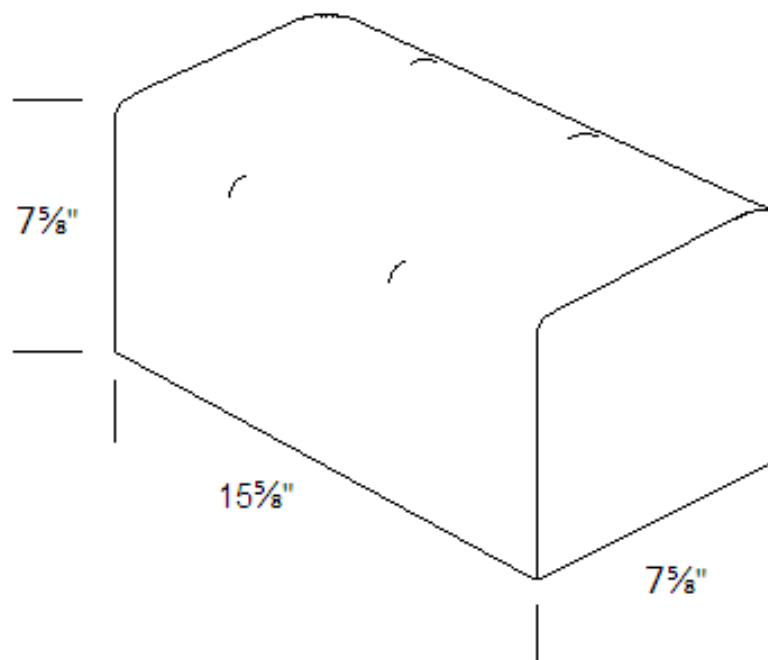

8x8x16 Solid Sill with 2" x 2" Chamfer

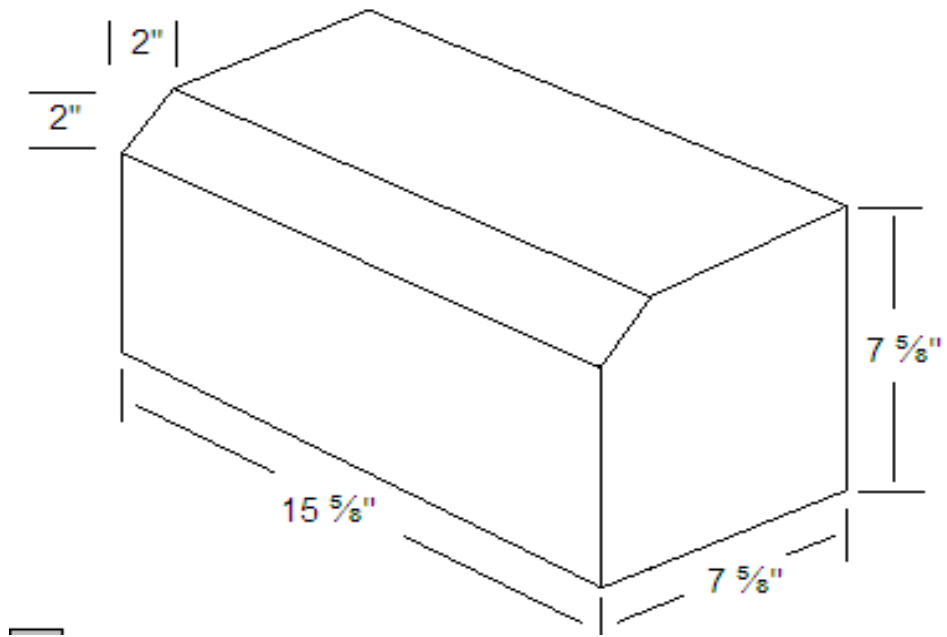

12x8x16 SILL with 2" x 2" CHAMFER

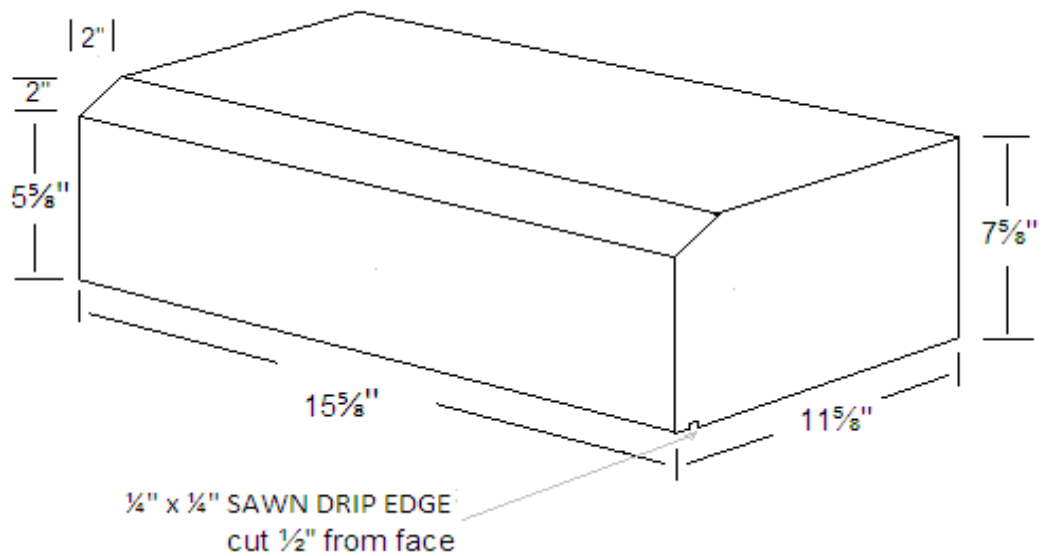

8" x 8" x 16" FULL BULLNOSE SILL

